

CSE 5522 Artificial Intelligence II

Homework #7: Bayes Nets

Wei Xu, Ohio State University

Your Name: _____ OSU ID: _____

1. **Independence.** Consider the Bayes' net shown below. (Please use the right one for clarity. The left one is just an equivalent but cuter version.)

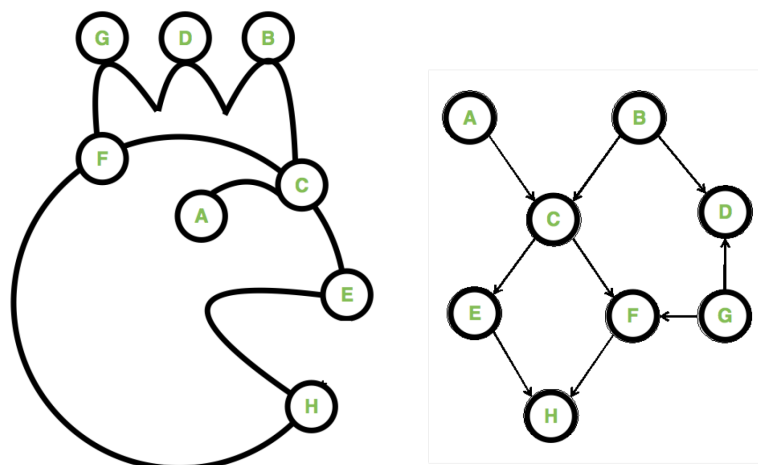

Remember that $X \perp\!\!\!\perp Y$ reads as “ X is independent of Y given nothing”, and $X \perp\!\!\!\perp Y \mid \{Z, W\}$ reads as “ X is independent of Y given Z and W .”

For each expression, fill in the corresponding circle to indicate whether it is True or False.

- (i) True False It is guaranteed that $A \perp\!\!\!\perp B \mid C$
- (ii) True False It is guaranteed that $A \perp\!\!\!\perp H$
- (iii) True False It is guaranteed that $A \perp\!\!\!\perp H \mid E$

- (iv) True False It is guaranteed that $E \perp\!\!\!\perp F \mid H$
- (v) True False It is guaranteed that $E \perp\!\!\!\perp F \mid C$
- (vi) True False It is guaranteed that $A \perp\!\!\!\perp F \mid \{C, D\}$
- (vii) True False It is guaranteed that $A \perp\!\!\!\perp F \mid \{C, G\}$
- (viii) True False It is guaranteed that $C \perp\!\!\!\perp G \mid H$

2. **Inference.** Suppose that a patient can have a symptom (S) that can be caused by two different diseases (A and B). It is known that the variation of gene G plays a big role in the manifestation of disease A . The Bayes' Net and corresponding conditional probability tables for this situation are shown below. For each part, you may leave your answer as an arithmetic expression.

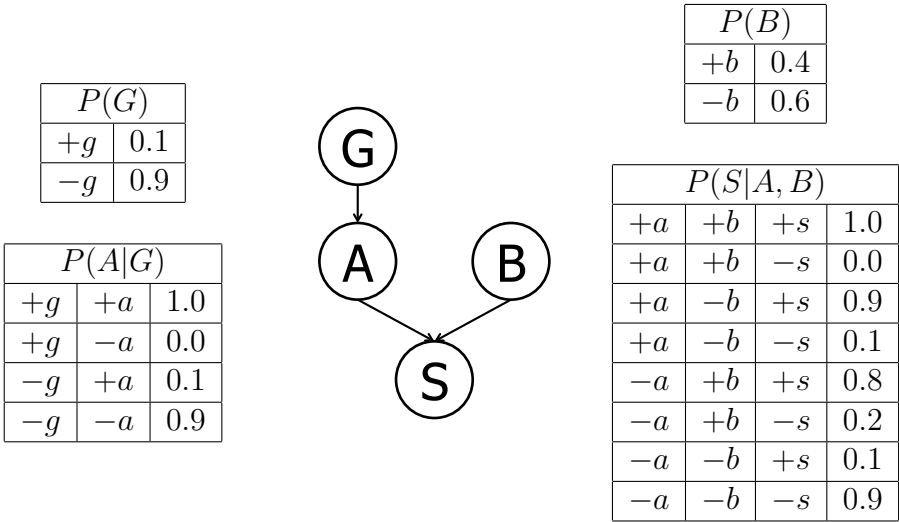

(a) Compute the following entry from the joint distribution:

$$P(+g, +a, +b, +s) =$$

- (b) What is the probability that a patient has disease A ?

$$P(+a) =$$

- (c) What is the probability that a patient has disease A given that they have disease B ?

$$P(+a | +b) =$$

- (d) What is the probability that a patient has disease A given that they have symptom S and disease B ?

$$P(+a | +s, +b) =$$

- (e) What is the probability that a patient has the disease carrying gene variation G given that they have disease A ?

$$P(+g | +a) =$$

- (f) What is the probability that a patient has the disease carrying gene variation G given that they have disease B ?

$$P(+g | +b) =$$